

# Advance AWD-320 & AWD-315 Wet/Dry Tank Vacuums

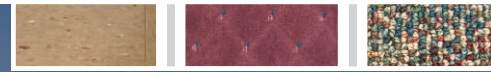

DEFINING  
CLEANING  
INNOVATION



A durable performer  
With a proven pedigree

 **Advance**  
by Nilfisk-Advance



# Advance AWD-320 & AWD-315 Wet/Dry Tank Vacuums

## Exceptional Performance Versatile Filtration

The Advance AWD series of commercial wet dry vacuums incorporate the technical excellence and attention to detail that have made Advance the brand of choice among cleaning professionals.

Advance AWD vacuums come in two sizes, 20 gallons and 15 gallons with identical foot prints. The blow molded tanks have a rear mounted drain hose that makes emptying the contents simple and clean. A 10 foot hose connects to the vacuum and utilizes our field proven locking vacuum interface. The adjustable handle easily accommodates users

of different heights and can be folded down over the top of the machine for easy transport.

A 50 foot safety yellow power cord provides the power to the 1,300 watt 2-stage motor. The water resistant switch is covered with a rubber boot and is rated for 20,000 on/off cycles.

Versatile dry filtration options are abundant on the AWD vacuums. Up to five levels of pre-fan filtration can be added to the machine. A basket filter comes standard and can be used along with the optional dust bag, cartridge filter and H.E.P.A. filter.

Liquid recovery is accomplished with either the two piece light weight aluminum wand and 14 inch squeegee tool or with the optional front mount squeegee assembly. The 24 or 30 inch front mount squeegee is the high productivity solution to recovering large amounts of liquids during emergencies or when stripping and refinishing floors.

## Ideal Applications Include —

- Education
- Government
- Hospitality
- Building Service Contractors
- Malls and Retail
- Healthcare

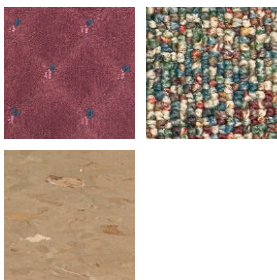

VALUE FEATURES



High productivity 14 inch floor tools



Compact footprint



Durable construction



Quiet sound



Adjustable handle folds over machine for easy transport



50 foot cord and 10 foot hose for long cleaning reach



Convenient cord storage over motor top handle



Gray non-marking wheels



Rear drain hose makes emptying a breeze



14 inch hard floor and squeegee tools

VALUE FEATURES



## The Advance AWD

- Unsurpassed Performance
- Exceptional Filtration
- Durable and Reliable
- Highest Value

### Defining Cleaning Innovation...

- Our products are designed using innovative technology that increases productivity and drives down the cost to clean.
- You can get expert service and maintenance for your Advance machines from factory-trained personnel around the world. Fast parts delivery, too.
- Maintain peak performance with Nilfisk Genuine OEM Parts.

 **Nilfisk** Genuine OEM Parts

## Tools and Accessories

- 24 inch front mount squeegee kit, includes 24 inch squeegee assembly, hose and mounting hardware 56 600 458
- 30 inch front mount squeegee kit, includes 30 inch squeegee assembly, hose and mounting hardware 56 600 459
- Dust bags, pack of 3 each 147 0746 010
- Upholstery tool 010 7964 020
- Crevice tool 010 8738 020
- Cartridge filter 140 8686 500
- H.E.P.A. Filter, H.E.P.A. protection ring required 140 8678 500
- H.E.P.A. Protection Ring Installation and use required for H.E.P.A. filtration 140 0766 500

## Technical Specifications

Models	AWD-320	AWD-315
Tank Capacity	20 gal (75.7 L)	15 gal (56.7 L)
Nominal Voltage	120 VAC/60 Hz	120 VAC/60 Hz
Vacuum Motor	1,350 W	1,350 W
Current Draw	11.2 Amps	11.2 Amps
Maximum Waterlift	95 in (241 cm)	95 in (241 cm)
Maximum Airflow	130 C.F.M. (61.3 L/s)	130 C.F.M. (61.3 L/s)
Sound Level	68 dB A	68 dB A
Washable Water Basket	225 in <sup>2</sup> (0.15 m)	225 in <sup>2</sup> (0.15 m)
Power Cord	50 ft (15 m)	50 ft (15 m)
Dimensions (H x W x D)	35 in x 17 in x 19 in (89 cm x 43 cm x 48 cm)	30.5 in x 17 in x 19 in (77 cm x 43 cm x 48 cm)
Weight with Cord and Tools	45 lb (20.4 kg)	42 lb (19 kg)
Part Numbers	905 8902 010	905 8901 010

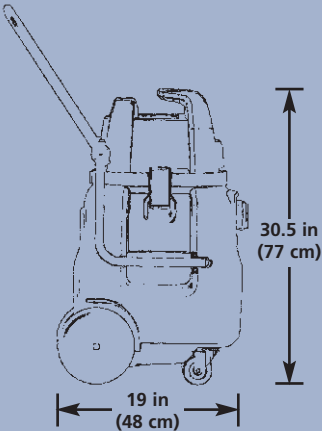

Specifications are subject to change without notice.



14600 21st Avenue North  
Plymouth, MN 55447-3408  
www.advance-us.com  
Phone: 800-850-5559  
Fax: 800-989-6566

396 Watline Avenue  
Mississauga, Ontario, Canada L4Z 1X2  
www.nilfisk-advance.com  
Phone: 800-668-8400 or 905-712-3260  
Fax: 800-263-5111 or 905-712-3255

©2006, Nilfisk-Advance, Inc., Printed in U.S.A., Form L1707A 6-06